



**MIKE 21 WAVE MODELLING**  
**MIKE 21 BW - Boussinesq Wave Module**  
**Short Description**

---



Agern Allé 5  
DK-2970 Hørsholm  
Denmark

Tel: +45 4516 9200  
Support: +45 4516 9333  
Fax: +45 4516 9292

[mikebydhi@dhigroup.com](mailto:mikebydhi@dhigroup.com)  
[www.mikebydhi.com](http://www.mikebydhi.com)

## **MIKE 21 BW - Boussinesq Wave Module**

MIKE 21 BW is the state-of-the-art numerical modelling tool for studies and analysis of wave disturbance in ports, harbours and coastal areas. The combination of an advanced GUI and efficient computational engines has made it an irreplaceable tool for professional coastal and harbour engineers around the world.

MIKE 21 BW has been used successfully for the analysis of operational and design conditions within ports and harbours. By the inclusion of surf and swash zone dynamics, the application range is extended further into the coastal engineering.



*MIKE 21 BW is a state-of-the-art numerical tool for studies and analysis of short and long period wave disturbance in ports and harbours*

MIKE 21 BW is capable of reproducing the combined effects of all important wave phenomena of interest in port, harbour and coastal engineering. These include:

- shoaling
- refraction
- diffraction
- wave breaking
- bottom dissipation
- moving shoreline
- partial reflection
- wave transmission
- non-linear wave-wave interactions
- frequency spreading
- directional spreading

MIKE 21 BW includes the two models:

- 2DH Boussinesq wave model
- 1DH Boussinesq wave model

The 2DH model covers two horizontal space-coordinates) and the 1DH model one horizontal space-co-ordinate (coastal profiles).

MIKE 21 BW is based on the numerical solution of the time domain formulations of Boussinesq type equations, Madsen et al (1991, 1992, 1997a,b), Sørensen and Sørensen (2001) and Sørensen et al (2004).

Both models solve the Boussinesq type equations using a flux-formulation with improved frequency dispersion characteristics. The enhanced Boussinesq type equations make the models suitable for simulation of propagation of non-linear directional waves from deep to shallow water.

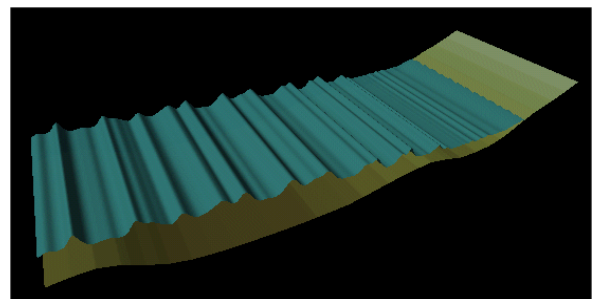
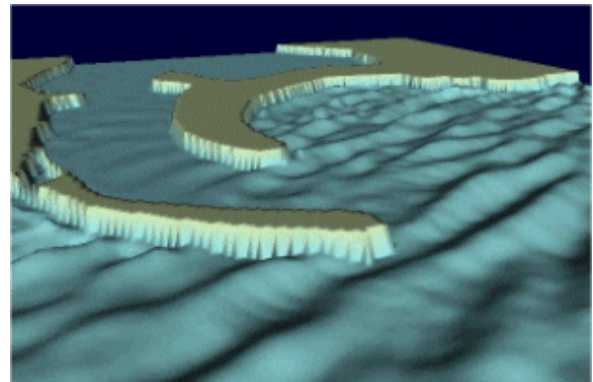

*MIKE 21 BW includes two models. The 2DH model (upper panel) is traditionally applied for calculation of wave disturbance in ports, harbours and coastal areas. The 1DH model (lower panel) is selected for calculation of wave transformation from offshore to the beach for the study of surf zone and swash zone dynamics*

## Application Areas

A major application area of MIKE 21 BW is determination and assessment of wave dynamics in ports and harbours and in coastal areas. The disturbance inside harbour basins is one of the most important factors when engineers are to select construction sites and determine the optimum harbour layout in relation to predefined criteria for acceptable wave disturbance, ship movements, mooring arrangements and handling down-time.

### 2DH Boussinesq Wave Model

Applications of the 2DH model include:

- determination of wave disturbance caused by wind-waves and swell
- analysis of low-frequency oscillations (seiching and harbour resonance) caused by forcing of e.g. short-wave induced long waves

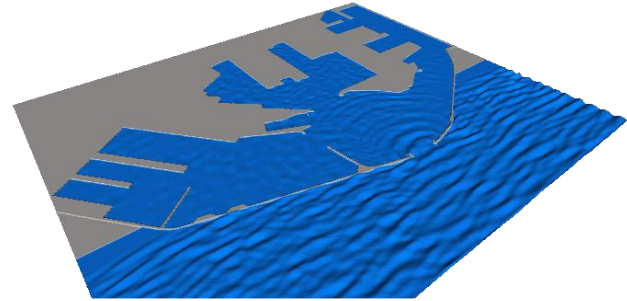

Simulation of wave penetration, Frederikshavn harbour, Denmark

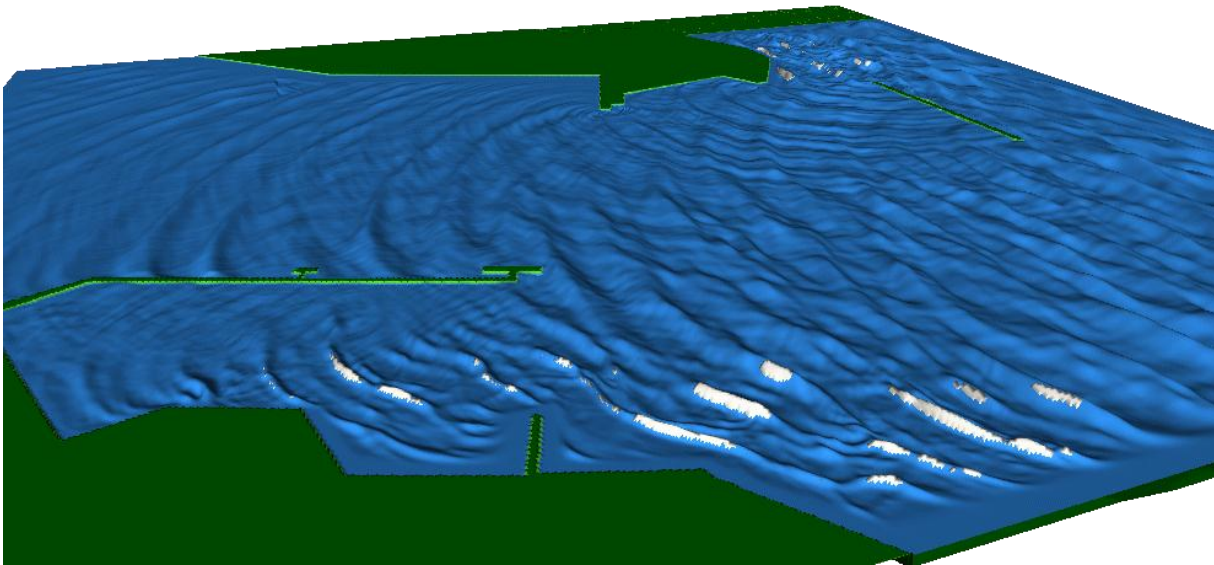

Simulation of wave propagation and agitation in a harbour area for an extreme wave event. The breaking waves (surface rollers) are shown in white

- wave transformation in coastal areas where reflection and/or diffraction are important phenomena
- surf zone calculations including wave-induced circulation and run-up/run-down
- simulation of propagation and transformation of transients such as ship-generated waves and tsunamis

The assessment of low-frequency motions in existing as well as new harbours is often performed by a combination of simulations with synthetic white-noise spectra and simulations with natural wave spectra. The purpose of the former type of simulation is to investigate the potential for seiching/resonance and identify the natural frequencies. This is particularly useful for comparisons of alternative layouts.

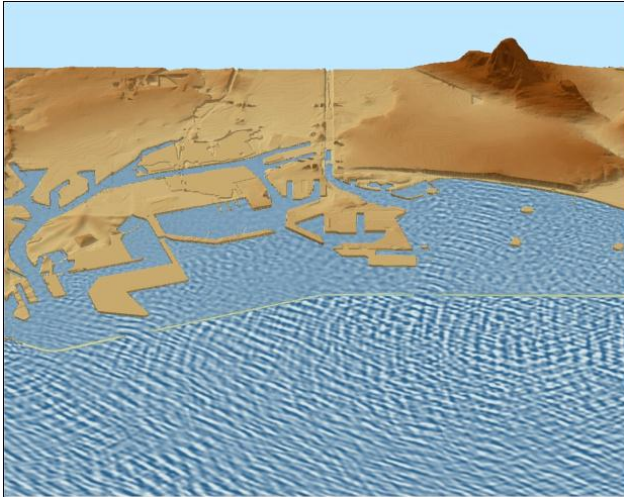

Wave transformation in Port of Long Beach, CA, USA

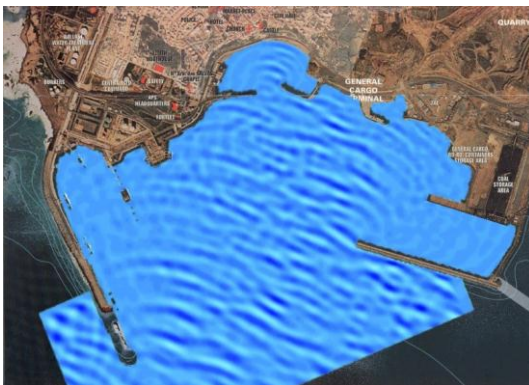

MIKE 21 BW application in Port of Sines, Portugal

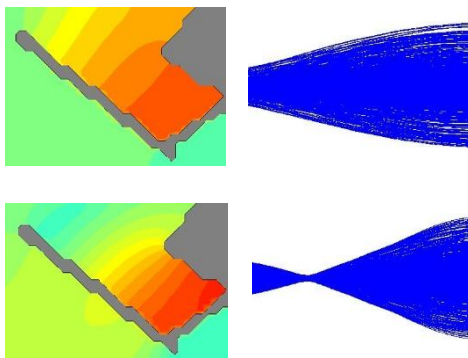

Natural fundamental modes of low-frequency oscillation. Long wave energy intensity and surface elevation envelopes along the longitudinal line of the basin. The digital filtering is performed the WSWAT analysis tool included in MIKE Zero

With inclusion of wave breaking and moving shoreline MIKE 21 BW is also an efficient tool for the study of many complicated coastal phenomena, e.g. wave induced-current patterns in areas with complex structures.

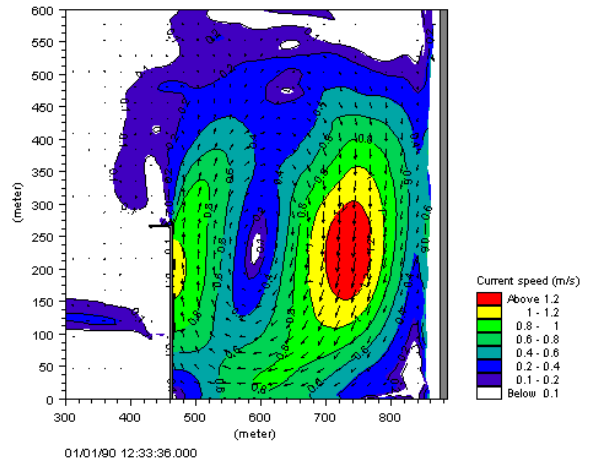
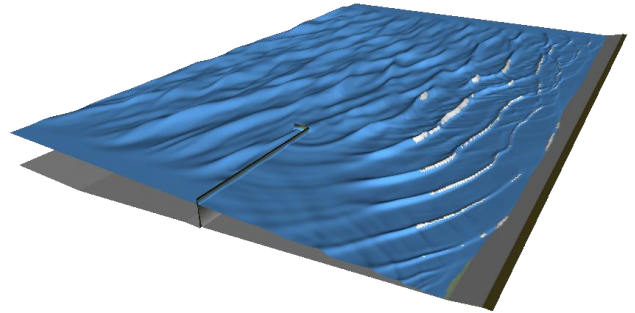

Wave transformation, wave breaking and run-up in the vicinity of a detached breakwater parallel to the shoreline. The lower image shows the associated circulation cell behind the breakwater

MIKE 21 BW is also applied for prediction and analysis of the impact of ship-generated waves (also denoted as wake wash) in ports and harbours and coastal areas. Essential boundary conditions (at open or internal boundaries) for the models can be obtained from 3D computational fluid dynamic (CFD) models, experimental data, full-scale data and/or empirical relationships.

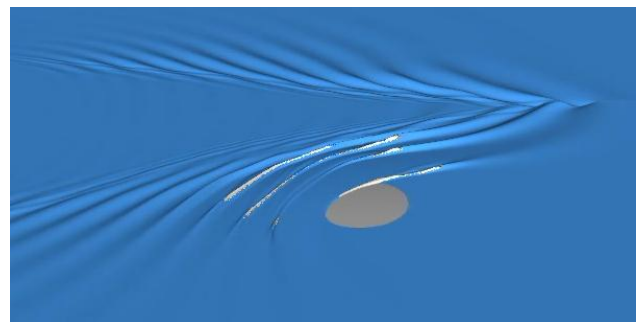

Wave breaking and run-up of ship waves on an offshore island

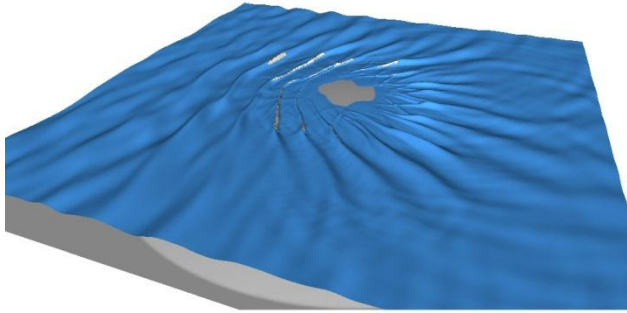

Wave transformation, wave breaking and run-up on an offshore island (directional wave input)

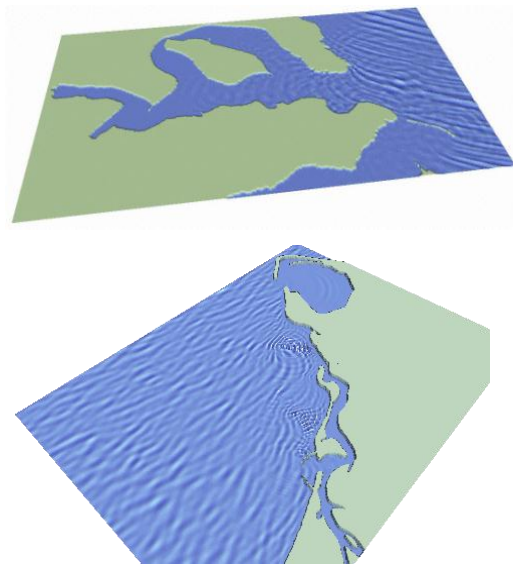

Examples of simulation of wave transformation in larger coastal areas using the 2DH model

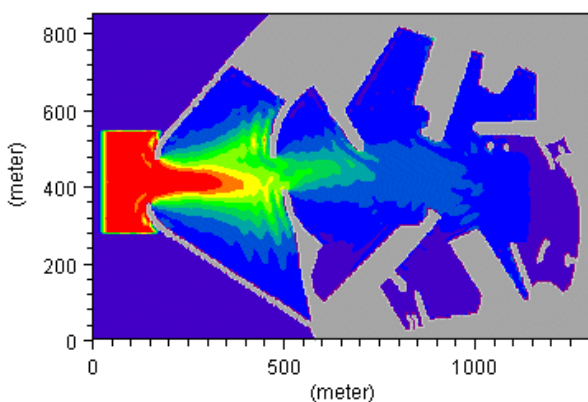

Wave disturbance in Rønne Harbour, Denmark

### 1DH Boussinesq Wave Model

Applications of the 1DH model include:

- computation of transformation of non-linear waves from deep water through the surf zone and to the beach
- analysis of generation and release of low-frequency waves
- analysis of wave breaking, undertow and run-up on dikes, revetments and beaches

The 1DH model can be applied for a number of transects (one spatial dimension) where surf zone and swash zone dynamics are simulated.

With the inclusion of wave breaking not only the spatial variation of e.g. the significant wave height, maximum wave height and wave set-up on the beach can be computed, but also details like the generation and release of low-frequency energy due to primary wave transformation can be computed. This is of significant importance for harbour resonance (seiching) and coastal processes.

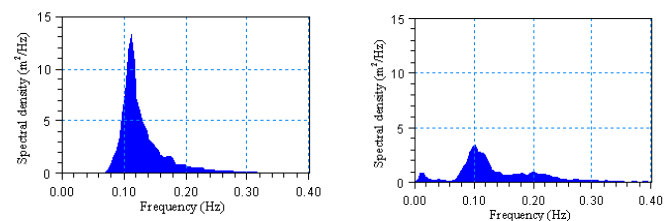
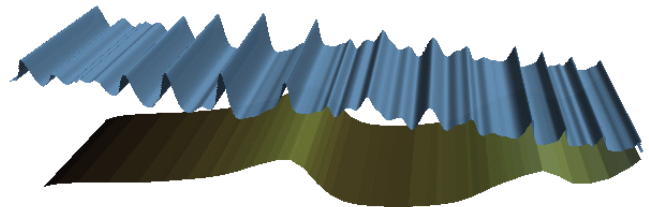

Transformation of irregular non-linear waves over a natural barred beach profile (upper panel). Offshore (left) and onshore (right) frequency wave spectra (lower panels). The spectra are computed using the WSWAT<sup>1</sup> analysis tool included in MIKE Zero (see page 14)

<sup>1</sup> WSWAT is a package within the MIKE Zero framework including a number of advanced modules for detailed wave analysis of time series data from physical model tests, numerical simulations or field measurements. WSWAT is a particularly a strong tool for analysing MIKE 21 BW output data in time and space.

## Model Equations

The Boussinesq wave models included in MIKE 21 BW solve the enhanced Boussinesq equations expressed in one or two horizontal dimensions in terms of the free surface elevation,  $\xi$ , and the depth-integrated velocity-components, P and Q.

The Boussinesq equations read:

### Continuity

$$n \frac{\partial \xi}{\partial t} + \frac{\partial P}{\partial x} + \frac{\partial Q}{\partial y} = 0$$

### x-momentum

$$n \frac{\partial P}{\partial t} + \frac{\partial}{\partial x} \left( \frac{P^2}{h} \right) + \frac{\partial}{\partial y} \left( \frac{PQ}{h} \right) + \frac{\partial R_{xx}}{\partial x} + \frac{\partial R_{xy}}{\partial x} + n^2 gh \frac{\partial \xi}{\partial x} + n^2 P \left[ \alpha + \beta \frac{\sqrt{P^2 + Q^2}}{h} \right] + \frac{gP\sqrt{P^2 + Q^2}}{h^2 C^2} + n\Psi_1 = 0$$

### y-momentum

$$n \frac{\partial Q}{\partial t} + \frac{\partial}{\partial y} \left( \frac{Q^2}{h} \right) + \frac{\partial}{\partial x} \left( \frac{PQ}{h} \right) + \frac{\partial R_{xy}}{\partial x} + \frac{\partial R_{yy}}{\partial x} + n^2 gh \frac{\partial \xi}{\partial y} + n^2 Q \left[ \alpha + \beta \frac{\sqrt{P^2 + Q^2}}{h} \right] + \frac{gQ\sqrt{P^2 + Q^2}}{h^2 C^2} + n\Psi_2 = 0$$

where the dispersive Boussinesq terms  $\Psi_1$  and  $\Psi_2$  are defined by

$$\Psi_1 = - \left( B + \frac{1}{3} \right) d^2 (P_{xx} + Q_{yy}) - nBg d^3 (\xi_{xxx} + \xi_{yyy})$$

$$- dd_x \left( \frac{1}{3} P_{xt} + \frac{1}{6} Q_{yt} + nBgd (2 \xi_{xx} + \xi_{yy}) \right)$$

$$- dd_y \left( \frac{1}{6} Q_{xt} + nBgd \xi_{xy} \right)$$

$$\Psi_2 = - \left( B + \frac{1}{3} \right) d^2 (Q_{yy} + P_{xx}) - nBg d^3 (\xi_{yyy} + \xi_{xxx})$$

$$- dd_y \left( \frac{1}{3} Q_{yt} + \frac{1}{6} P_{xt} + nBgd (2 \xi_{yy} + \xi_{xx}) \right)$$

$$- dd_x \left( \frac{1}{6} P_{yt} + nBgd \xi_{xy} \right)$$

Subscripts x, y and t denote partial differentiation with respect to space and time, respectively.

The incorporation of wave breaking is based on the concept of surface rollers, where the terms denoted  $R_{xx}$ ,  $R_{xy}$  and  $R_{yy}$  account for the excess momentum originating from the non-uniform velocity distribution due to the presence of the surface roller.  $R_{xx}$ ,  $R_{xy}$  and  $R_{yy}$  are defined by:

$$R_{xx} = \frac{\delta}{1 - \delta/h} \left( c_x - \frac{P}{h} \right)^2$$

$$R_{xy} = \frac{\delta}{1 - \delta/h} \left( c_x - \frac{P}{h} \right) \left( c_y - \frac{Q}{h} \right)$$

$$R_{yy} = \frac{\delta}{1 - \delta/h} \left( c_y - \frac{Q}{h} \right)^2$$

Here  $\delta = \delta(t, x, y)$  is the thickness of the surface roller and  $c_x$  and  $c_y$  are the components of the roller celerity.

The enhanced Boussinesq type equations make the models suitable for simulation of the propagation of directional wave trains travelling from deep to shallow water.

### Symbol list

$P$	flux density in the x-direction ( $m^3/m/s$ )
$Q$	flux density in the y-direction ( $m^3/m/s$ )
$B$	Boussinesq dispersion coefficient (-)
$x, y$	Cartesian co-ordinates (m)
$t$	time (s)
$h$	total water depth ( $=d+\xi$ )
$d$	still water depth (m)
$g$	gravitational acceleration ( $= 9.81 m/s^2$ )
$n$	porosity (-)
$C$	Chezy resistance number ( $m^{0.5}/s$ )
$\alpha$	resistance coefficient for laminar flow in porous media (-)
$\beta$	resistance coefficient for turbulent flow in porous media (-)
$\xi$	water surface elevation above datum (m)

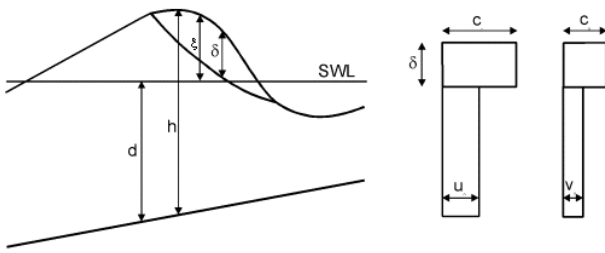

Cross-section of a breaking wave and the assumed vertical profile of the horizontal particle velocity components

The maximum depth to deep-water wavelength is  $h/L0 \approx 0.5$  (or  $kh \approx 3.1$ , where  $kh$  is the relative wave number) for  $B= 1/15$ . For the classical Boussinesq equations ( $B= 0$ ) the maximum depth to deep-water wavelength is  $h/L0 \approx 0.22$  (or  $kh \approx 1.4$ ).

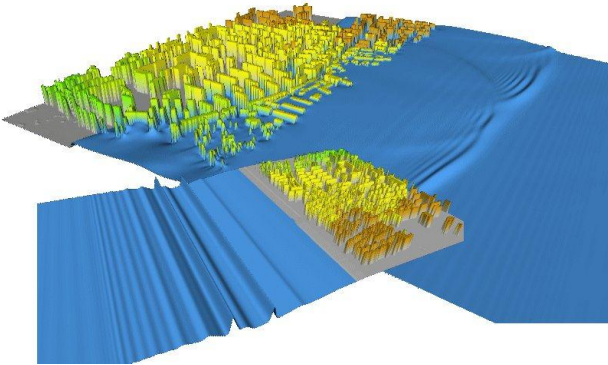

Wave propagation and transformation of a tsunami in an urbanised coastal area simulated by MIKE 21 BW 2DH

### 1DH Boussinesq Wave Model

The 1DH model of MIKE 21 BW solves the enhanced Boussinesq equations by a standard Galerkin finite element method with mixed interpolation.

One of the main problems when solving Boussinesq type equations using finite element techniques is the presence of higher-order spatial derivatives. In MIKE 21 BW this problem is handled by using an approach where the Boussinesq type equations are written in a lower order form by introducing a new auxiliary variable  $w$  and an auxiliary algebraic equation. The governing equations then have the following form:

#### Continuity

$$n \frac{\partial \xi}{\partial t} + \frac{\partial P}{\partial x} = 0$$

#### Momentum

$$n \frac{\partial P}{\partial t} + \frac{\partial}{\partial x} \left( \frac{P^2}{h} \right) + \frac{\partial R_{xx}}{\partial x} + n^2 gh \frac{\partial \xi}{\partial x} - n(B + \frac{1}{3})d^2 \frac{\partial^3 P}{\partial x \partial x \partial t} + \frac{1}{3}d \frac{\partial d}{\partial x} \frac{\partial^2 P}{\partial x \partial t} - n^2 Bgd^2 \frac{\partial w}{\partial x} + n^2 P \left[ \alpha + \beta \frac{|P|}{h} \right] + \frac{gP|P|}{h^2 C^2} = 0$$

#### Auxiliary variable $w$

$$w = \frac{\partial}{\partial x} \left( d \frac{\partial \xi}{\partial x} \right)$$

These equations only contain terms with second order derivatives with respect to the spatial coordinates. Recasting these equations into a weak form using the standard Galerkin finite element method and applying the divergence theorem to the dispersive Boussinesq type terms, the equations can be written in a form, which only requires the interpolation functions to be continuous as described in Sørensen et al (2004).

### Solution Methods

The numerical implementation is different for the two models.

#### 2DH Boussinesq Wave Model

The differential equations are spatially discretised on a rectangular, staggered grid as illustrated below. Scalar quantities such as water surface elevation are defined in the grid nodes, whereas flux components are defined halfway between adjacent grid nodes in the respective directions.

The finite-difference approximation of the spatial derivatives is a straightforward mid-centring, except for the convective terms, which are described in detail in Madsen and Sørensen (1992) and Madsen et al (1997a).

The integration in time is performed using a time-centred implicit scheme. The applied algorithm is a non-iterative Alternating Direction Implicit (ADI) algorithm, using a 'fractional step' technique and 'side-feeding' (semi-linearization of non-linear terms). The resulting tri-diagonal systems of equations are solved by the Double Sweep Algorithm.

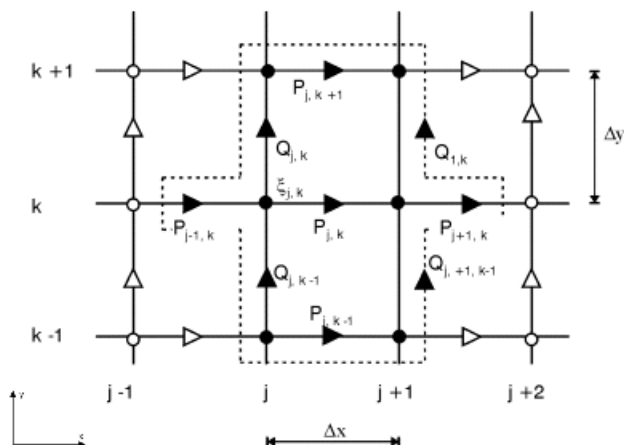

Staggered grid in x-y-space

### 1DH Boussinesq Wave Model

Finite element solutions of the Boussinesq equations in primitive form can exhibit severe spurious modes especially when equal-order interpolation functions are applied for the fluxes and the surface elevation. To get stable and oscillation free solutions, mixed interpolation is used in the present version of the model. Elements with quadratic fluxes and linear surface elevation and auxiliary variable are applied.

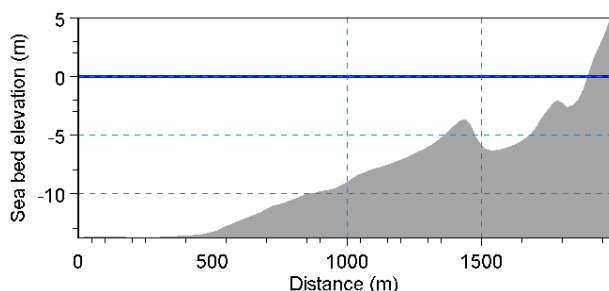

An example of a bathymetry used in MIKE 21 BW 1DH

The integration in time is performed using either an explicit three step Taylor-Galerkin scheme or a predictor-corrector method (4<sup>th</sup>-order Adams-Bashforth-Moulton method).

To obtain the auxiliary variable and the derivatives with respect to time of the fluxes and surface elevation, three sets of linear equations have to be solved. For small problems, these systems can be solved using Gaussian elimination with sparse technique. For larger systems more cost-efficient methods are used such as a Krylov subspace iterative method (e.g. GMRES) combined with an efficient pre-conditioner (e.g. incomplete LU factorisation). Both methods are implemented in MIKE 21 BW.

### Model Input Data

The necessary input data to the two models in MIKE 21 BW can be divided into the following groups:

- Basic data:
  - bathymetry
  - type of model and equations
  - numerical parameters
  - type of boundaries
  - time step and length of simulation
- Calibration data:
  - initial conditions
  - boundary data
  - internal wave generation data
  - wave breaking
  - moving shoreline
  - bottom friction
  - partial wave reflection/transmission
  - wave absorbing
- Output data:
  - deterministic output
  - phase-averaged output
  - wave disturbance output
  - hot start output
  - moving shoreline output

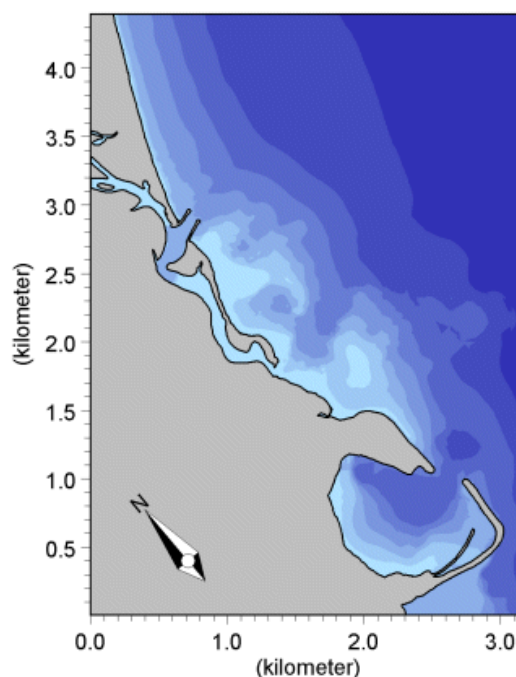

Example of bathymetry used in the MIKE 21 BW 2DH model

The main task in preparing the input data for the MIKE 21 BW models is to generate a bathymetry, maps of porosity and sponge layers. Porosity layers are used to model either partial reflection and/or transmission through porous structures. For areas where wave radiation is required absorbing sponge layers are specified.

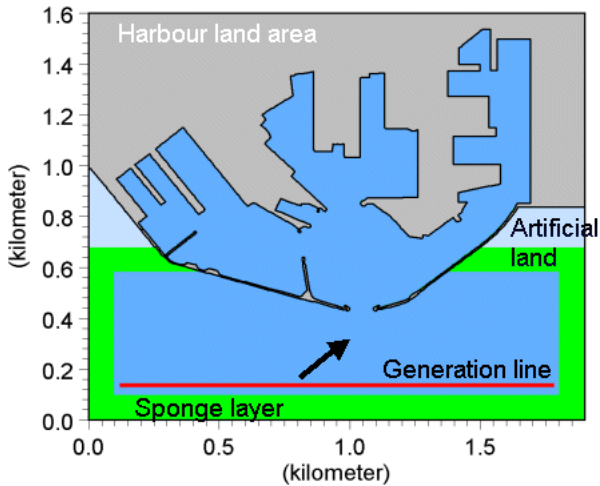

Example of a map including sponge layer and internal wave generation data

The Bathymetry Editor, which is included in the MIKE 21 PP (Pre- and Post-processing) package, provides an efficient work environment for creating, editing and presenting detailed digital bathymetries. Tools for preparation of porosity and sponge layer maps are included in the MIKE 21 Toolbox as illustrated below.

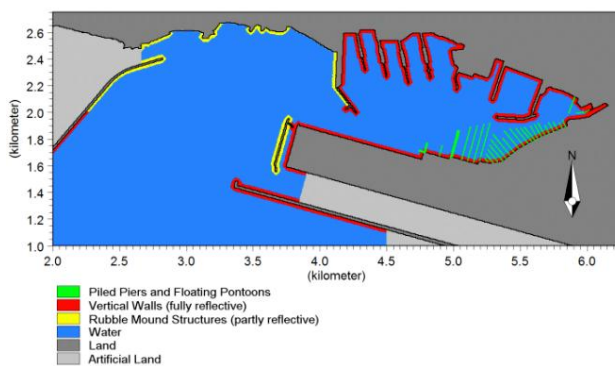

Example of a map including porosity layers for modelling of partial reflection/transmission

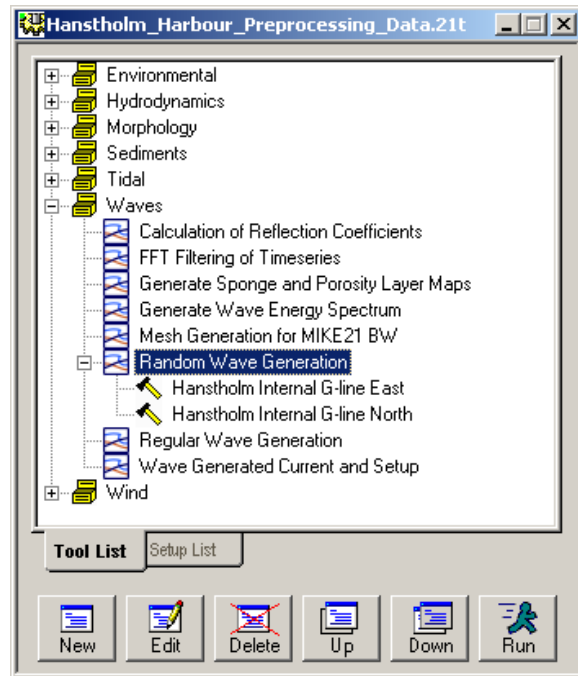

Graphical user interface of the MIKE 21 Toolbox

Incident waves are specified through boundary conditions. The waves may either be specified along open boundaries or be generated internally within the model.

At open boundaries, the incident wave energy is given as time series of surface elevations (level boundary) or flux densities perpendicular to the boundary (flux boundary). For the enhanced Boussinesq equations additional information about the derivatives of the surface elevation is required. As outgoing waves will be reflected from an open boundary, this type of boundary is applied when no or minor reflection is expected from the model area.

With internal wave generation it is possible to generate fully directional waves or unidirectional waves propagating with an angle to the generation line. The generation line is placed in front of a sponge layer absorbing all outgoing waves.

Boundary or internal generation data is easily prepared using the tools included in the MIKE 21 Toolbox. The tools support the most widely used type of frequency spectra as well as user-defined spectra and directional distributions. The Toolbox is also capable of generating regular waves of Cnoidal type, Stokes type or Boussinesq type.

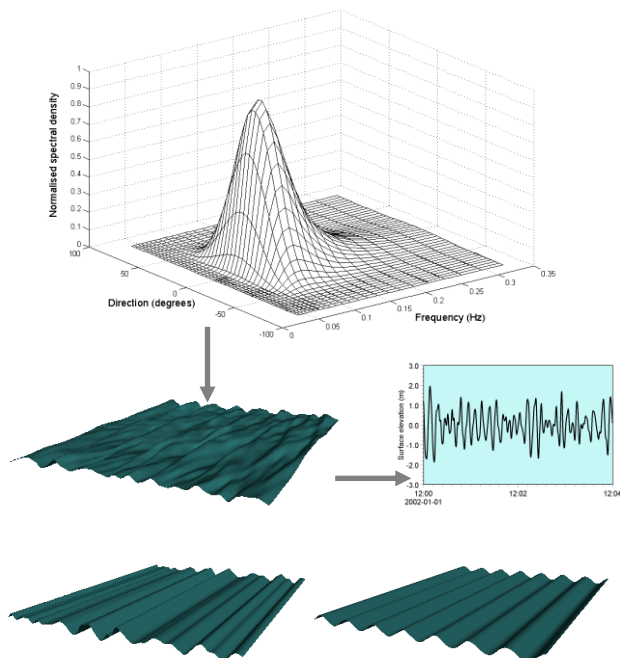

MIKE 21 BW supports input data representing directional, unidirectional and regular wave conditions

### Model Output

Five types of output data can be obtained from the model:

- Deterministic parameters
- Phase-averaged parameters
- Wave disturbance parameters (2DH only)
- Hot start parameters (2DH only)
- Moving shoreline parameters (1DH only)

Deterministic parameter data basically consist of time series of surface elevations and depth-integrated velocity components. Phase-averaged parameters are obtained by user defined time-integration of derived variables.

All type of output data can be post-processed, analysed and presented in various graphical forms using the pre- and post-processing module, MIKE 21 PP as well as other tools within the MIKE Zero framework.

Examples are:

- Time series plots (0D, 2D and 3D)
- Data checking by graphical and tabular view
- Statistics
- 2D/3D animations (e.g. AVI)
- Time series analysis (using WSWAT) analysis
- GIS presentation (using DHI Marine GIS Extension for ArcGIS®)

Binary output data may also be loaded directly into a MATLAB® workspace using DHI's DFS Functions for MATLAB®, which can be downloaded from:

<http://www.dhisoftware.com/mike21/Download/Tools/matlabdfs.htm>



Output from MIKE 21 BW 2DH. The panel to the left shows a map of the instantaneous surface elevation. The right panel shows the map of the corresponding wave disturbance coefficients. Nykøbing Mors harbour, Denmark

### Deterministic Output Parameters



The deterministic output dialog of MIKE 21 BW allows the user to save time series of surface elevations in points, along transects or in domain areas for subsequent analysis and visualisation

The following deterministic output parameters can be selected from the user interface:

- Surface elevation
- Water level
- $P$  flux
- $Q$  flux
- Still water depth
- Auxiliary variable
- Roller thickness
- Roller angle
- Roller celerity  $c_x$
- Roller celerity  $c_y$
- Water level (roller)

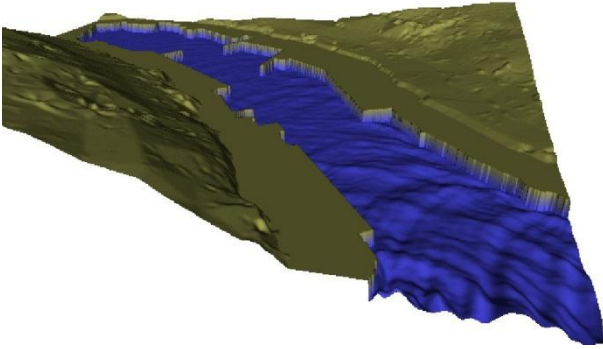

Example of deterministic output (instantaneous surface elevation), Klaksvik, Faeroe Islands

### Phase-averaged Output Parameters



The phase-averaged output dialog of MIKE 21 BW allows the user to save a large number of commonly used derived variables

It is possible to select between the following two types of phase-averaged wave statistics:

- Cumulative statistics
- Subseries statistics

and whether or not the phase averaging should cover the swash zone. If "cumulative statistics" is selected, the output items will be updated regularly corresponding to a specified update interval. In the case of "subseries statistics", the output items will be set to zero at the update interval.

The following phase-averaged output parameters can be selected from the user interface:

- Significant wave height
- Maximum wave height
- Maximum surface elevation
- Minimum surface elevation
- Mean surface elevation
- Mean flux,  $P$
- Mean flux,  $Q$
- Mean velocity,  $u_0$
- Mean velocity,  $v_0$
- Mean roller thickness
- Skewness
- Kurtosis
- Atiltness
- Radiation stress (1DH only)

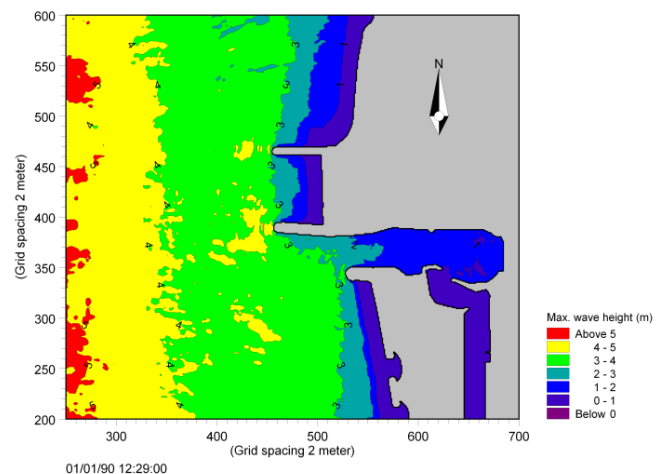

Output from MIKE 21 BW 2DH. Maximum wave height, Torsminde Harbour, Denmark

### Wave Disturbance Output Parameters (2DH only)



MIKE 21 BW is the optimal tool for design of new terminals

The wave disturbance coefficient is defined as the ratio of the significant wave height relative to the incoming significant wave height. If e.g. the wave height at a given position is 0.5 m and the incoming (offshore) wave height is 2.0 m, then the wave disturbance coefficient is  $0.5/2.0 = 0.25$ , or 25 %.

The following wave disturbance related output parameters can be selected from the user interface:

- Significant wave height,  $H_{m0}$
- Wave disturbance coefficient,  $H_{m0}/H_{m0,incoming}$
- Time of arrival of the first wave

Additional wave statistics for the areas defined in a so-called "Area Code Map" file can be extracted. The statistics cover following parameters:

- Maximum wave disturbance
- Minimum wave disturbance
- Mean wave disturbance
- Standard deviation
- Number of data for each defined area

The additional wave statistics output is saved in an ASCII text file, which can be viewed by a common text editor or imported into a spreadsheet.

### Moving Shoreline Output Parameters (1DH only)



MIKE 21 BW can be used to study swash zone oscillations and run-up

The moving shoreline output parameters consists of time series containing the following three output items:

- Horizontal run-up
- Vertical run-up
- Total run-up

### Hot Start Output Parameters (2DH only)

The hot start facility in MIKE 21 BW allows starting a simulation as a continuation of an earlier run. To enable this, details of the finishing conditions of earlier simulations must have been saved in a hot data.

This type of output is mainly used for 2DH applications involving wave-current interactions, where the wave simulation is hot started from a run with currents only.

### Examples of output from 1DH model

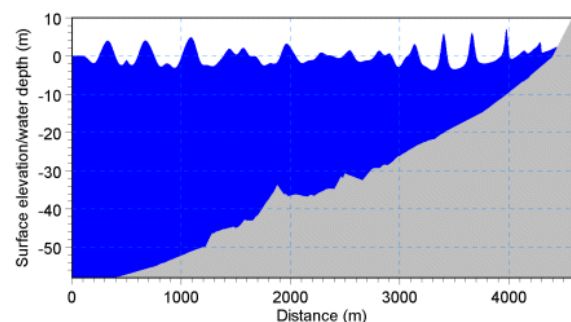

Output from MIKE 21 BW 1DH. The panel shows the instantaneous surface elevation on a sloping beach

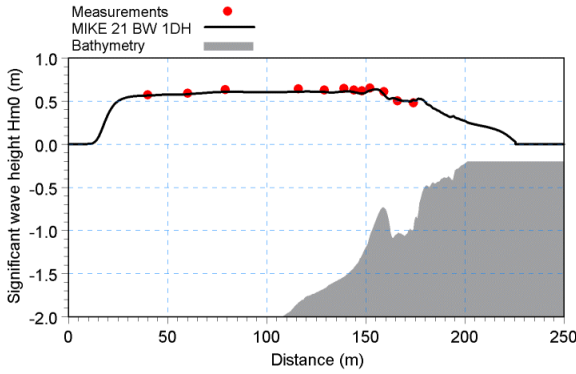

Comparison between measured and simulated significant wave height on a barred beach

### Validation

MIKE 21 BW has successfully been applied to a large number of rather basic idealised situations for which the results can be compared with analytical solutions or information from the literature. The results are presented in various internationally accepted journals, see the reference section.

The models have also been validated under natural geophysical conditions, which are more realistic and complex than the academic and laboratory tests, see references on applications.

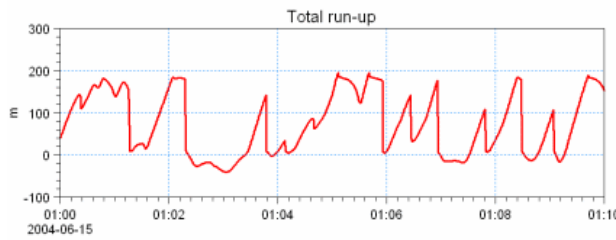
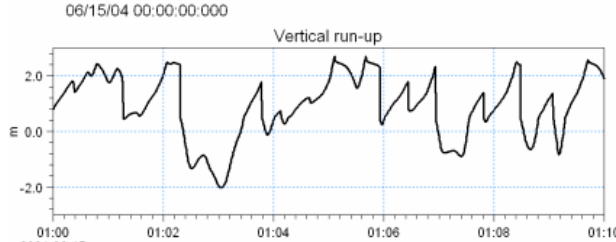
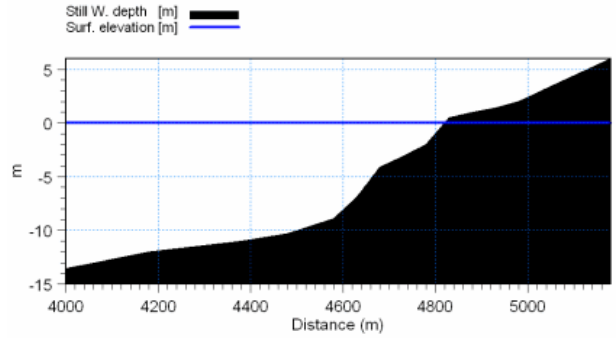

Example of moving shoreline output parameters; vertical and horizontal wave run-up on a coast (irregular waves)

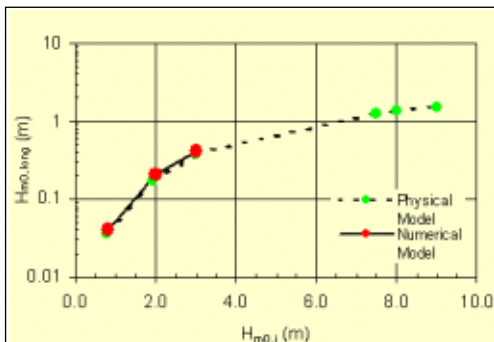

Comparison between measured and simulated significant wave height. Beirut Marina, Lebanon

### MIKE 21 BW Model Setup Planner



**Define your model**

Max. water depth (m)

Min. water depth (m)

Model extent in X-direction (m)

Model extent in Y-direction (m)

Percentage of water points (%)

Max. distance for waves to propagate (m)

Time required for calculation of statistics (minutes prototype time)

Computational points per CPU second<sup>2)</sup>

Spectral peak period (s)

Exclude wave breaking/moving shoreline

Include wave breaking/moving shoreline

**Calculate and check/evaluate  $T_{min}$ , dx and dt<sup>1)</sup>**

**B: Calculate default upper limits**

Upper limits	Classical eq.	Enhanced eq.
Min. wave period, $T_{min}$ (s)	5.66	3.76
Max. spatial resolution, dx (m)	5.07	2.88
Max. time step, dt (s)	0.487	0.107

**C: Update upper limits using  $T_{min}$  and check/evaluation**

**Own suggestion**

	Classical eq.	Enhanced eq.
Min. wave period, $T_{min}$ (s)	5.66	3.76
Spatial resolution <sup>4)</sup> , dx (m)	5.07	2.88
Time step, dt (s)	0.487	0.107

**Check/evaluation of selected  $T_{min}$ , dx and dt**

	Classical eq.	Enhanced eq.
Max. ratio $h/L_G$ for $T_{min}$	0.2196	0.4978
Max. ratio $h/L_G$ for $T_p$	0.0432	0.0432
Min. ratio $L/dx$ for $T_{min}$	7.0011	7.0165
Min. ratio $L/dx$ for $T_p$	11.345	19.972
Ratio $T/dt$ for $T_{min}$	11.622	35.140
Ratio $T/dt$ for $T_p$	17.659	80.373
Max. Courant Number	0.9983	0.3861
Estimated CPU time (hours)	0.1614	2.2675
Estimated RAM (MB)	9.9601	18.221

**Calculate simulation period**

**A: Total simulation time**

Total time required for simulation (minutes prototype time)<sup>3)</sup>

**Legend:** OK Not OK

**Notes:** 1) The MIKE 21 BW Model Setup Planner is based on the step-by-step procedure shown [here](#).

MIKE21 BW includes a number of Java scripts for efficient model set-up and execution

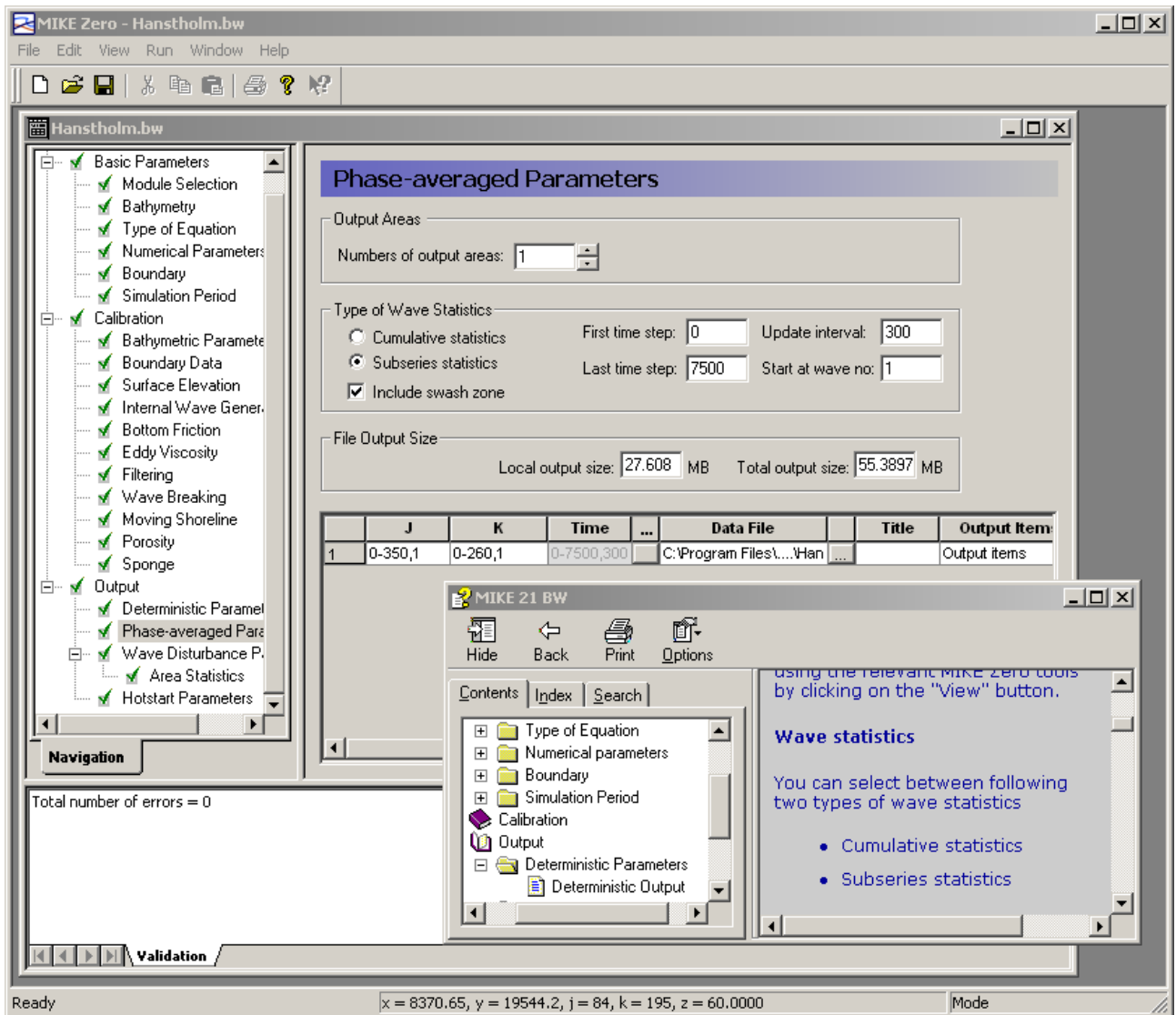

The graphical user interface of the MIKE 21 BW model including an example of the Online Help system

### Graphical User Interface

MIKE 21 BW is operated through a fully Windows integrated Graphical User Interface. Support is provided at each stage by an Online Help system.

The common MIKE Zero shell provides entries for common data file editors, plotting facilities and a toolbox for/utilities as the Bathymetry Editor.

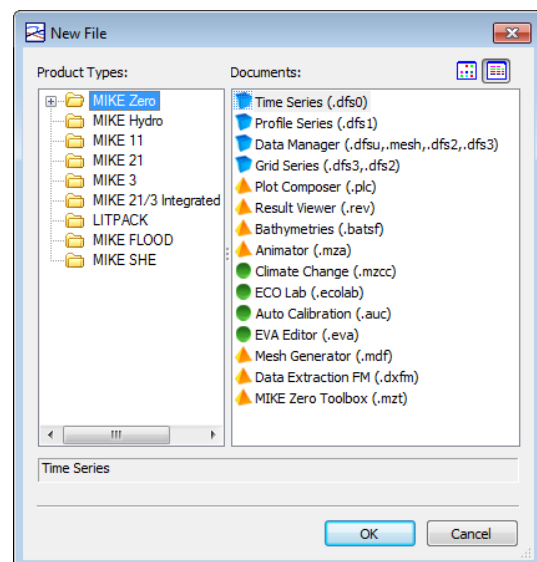

Overview of the common MIKE Zero utilities

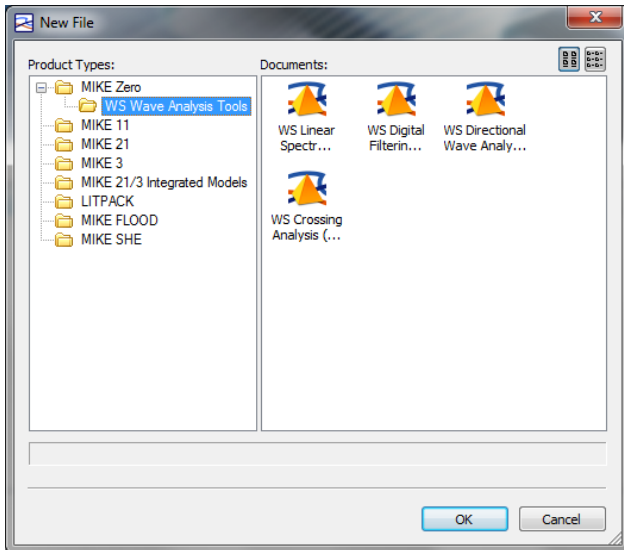

*WS Wave Analysis Tools included in MIKE Zero is a package of advanced modules for detailed wave analysis of time series data from numerical model simulations*

## Hardware and Operating System Requirements

MIKE 21 BW supports Microsoft Windows XP and Microsoft Windows Vista. Microsoft Internet Explorer 5.0 (or higher) is required for network license management as well as for accessing the Online Help.

The recommended minimum hardware requirements for executing MIKE 21 BW are:

Processor:	3 GHz PC (or higher)
Memory (RAM):	4 GB (or higher)
Hard disk:	160 GB (or higher)
Monitor:	SVGA, resolution 1024x768
Graphic card:	32 MB RAM (or higher), 32 bit true colour
Media:	CD-ROM/DVD drive, 20 x speed (or higher)

## Parallelisation

The computational engine of the MIKE 21 BW module is has been parallelised using shared memory (OpenMP) architecture. The result is faster simulations on systems with multiple cores.

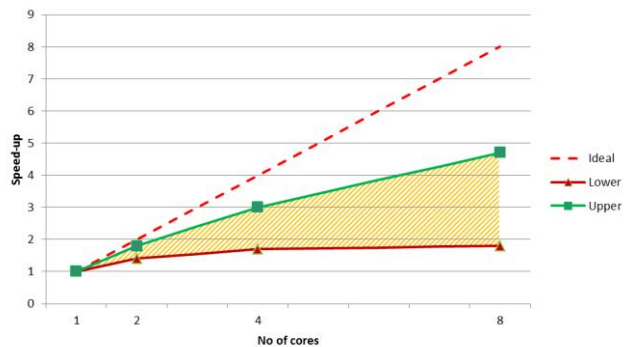

*MIKE 21 BW speed-up using multicore PCs for Release 2011 with shared memory architecture. Shaded area indicates typical speed-up range.*

## Support

News about new features, applications, papers, updates, patches, etc. are available here:

[www.mikebydhi.com/Download/DocumentsAndTools.aspx](http://www.mikebydhi.com/Download/DocumentsAndTools.aspx)

For further information on MIKE 21 BW, please contact your local DHI office or the Software Support Centre:

MIKE by DHI  
 DHI  
 Agern Allé 5  
 DK-2970 Hørsholm  
 Denmark  
 Tel: +45 4516 9333  
 Fax: +45 4516 9292  
[www.mikebydhi.com](http://www.mikebydhi.com)  
[mikebydhi@dhigroup.com](mailto:mikebydhi@dhigroup.com)

## References

- Sørensen, O.R., Schäffer, H.A. and Sørensen, L.S., 2004. Boussinesq type modelling using an unstructured finite element technique. *Coastal Eng.*, 50, 181-198.
- Sørensen, O.R. and Sørensen, L.S., 2001. Boussinesq type modelling using unstructured finite element technique. In *Proc. 27th Coastal Eng. Conf.* 190-202.
- Madsen, P.A., Sørensen, O.R. and Schäffer, H.A., 1997a. Surf zone dynamics simulated by a Boussinesq type model. Part I: Model description and cross-shore motion of regular waves. *Coastal Eng.*, 32, 255-288.
- Madsen, P.A., Sørensen, O.R. and Schäffer, H.A., 1997b. Surf zone dynamics simulated by a Boussinesq type model. Part II: Surf beat and swash zone oscillations for wave groups and irregular waves. *Coastal Eng.*, 32, 289-320.
- Madsen, P. A. and Sørensen, O. R., 1992. A New Form of the Boussinesq Equations with Improved Linear Dispersion Characteristics, Part 2: A Slowly-varying Bathymetry. *Coastal Eng.*, 18, 183-204.
- Madsen, P.A., Murray, R. and Sørensen, O. R., 1991. A New Form of the Boussinesq Equations with Improved Linear Dispersion Characteristics (Part 1). *Coastal Eng.*, 15, 371-388.
- Madsen, P.A., 1983. Wave Reflection from a Vertical Permeable Wave Absorber. *Coastal Eng.*, 7, 381-396.
- Abbott, M. B., Petersen, H. M. and Skovgaard, O., 1978. On the Numerical Modelling of Short Waves in Shallow Water. *J. Hydr. Res.*, 16, 173-204.



*MIKE 21 BW includes wave breaking (surface rollers)*

## Selected references on applications

- Kofoed-Hansen, H., Kerper, D.R., Sørensen, O.R., Kirkegaard, J., 2005. Simulation of long wave agitation in ports and harbours using a time-domain Boussinesq model. In preparation.
- Gierlevsen, T., Hebsgaard, M. and Kirkegaard, J., 2001. Wave disturbance modelling in Port of Sines, Portugal - with special emphasis on long period oscillations. In *Proc. International Conference on Port and Maritime R&D and Technology, Singapore, 29-21 October 2001*, 337-344.
- Kofoed-Hansen, H., Slot, P., Sørensen O.R. and Fuchs, J., 2001. Combined numerical and physical modelling of seiche in exposed new marina. In *Proc. 27th International Conference of Coastal Engineering*, 3600-3614.
- Kuang-ming, Y., Rugbjerg, M. and Kej, A., 1987. Numerical modelling of harbour disturbance in comparison with physical modelling and field measurements. *Proc. Second Int. Conf. on Coastal and Port Eng. in Developing Countries, Beijing, China.*
- Berenguer, I., Rugbjerg, M., Madsen, P. A. and Kej, A., 1986. Mathematical and physical wave disturbance modelling-complementary tools. *Proc. 20th Int. Conf. on Coastal Eng., Taipei, 9-14 November 1986.*

